



# ROTOR

**UPGRADE  
YOURSELF**

**ROTOR TECHNICAL INFO**

© ROTOR Bike Components 2012

# **Q-Ring / FD setup**

Front derailleur setup guide

# Q-Rings

## FRONT DERAILLEUR SETUP

- All chainrings, round or oval require a quality FD setup. With oval rings, Sloppy setup = disastrous shifting!
- No specialist skills are required. When setup is correct, Q-Rings shift just as well as all other round chainrings.

### 6 SETUP RULES:

- 1) Perfectly parallel chainrings and derailleur cage.

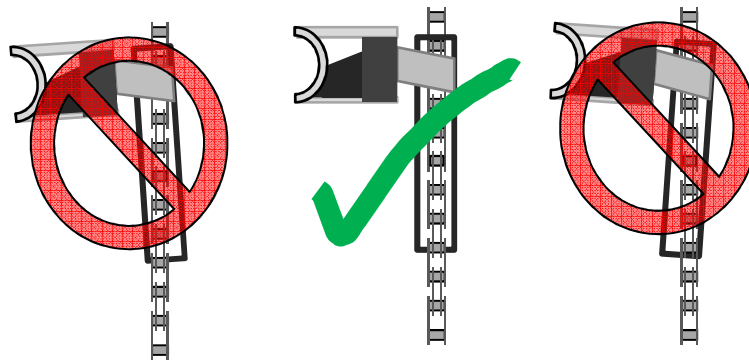

# Q-Rings

## FRONT DERAILLEUR SETUP

- All chainrings, round or oval require a quality FD setup. With oval rings, Sloppy setup = disastrous shifting!
- No specialist skills are required. When setup is correct, Q-Rings shift just as well as all other round chainrings.

### 6 SETUP RULES:

- 1) Perfectly parallel chainrings and derailleur cage.
- 2) Derailleur limitation screws must be set up to prevent over and under shifts.

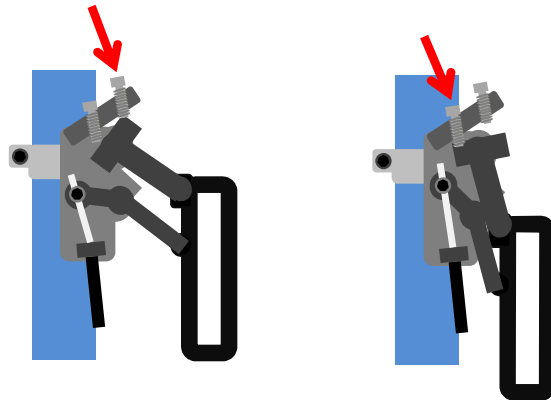

# Q-Rings

## FRONT DERAILLEUR SETUP

- All chainrings, round or oval require a quality FD setup. With oval rings, Sloppy setup = disastrous shifting!
- No specialist skills are required. When setup is correct, Q-Rings shift just as well as all other round chainrings.

### 6 SETUP RULES:

- 1) Perfectly parallel chainrings and derailleur cage.
- 2) Derailleur limitation screws must be set up to prevent over and under shifts.
- 3) No more than 1,5mm clearance form top of teeth to bottom of cage at max diameter

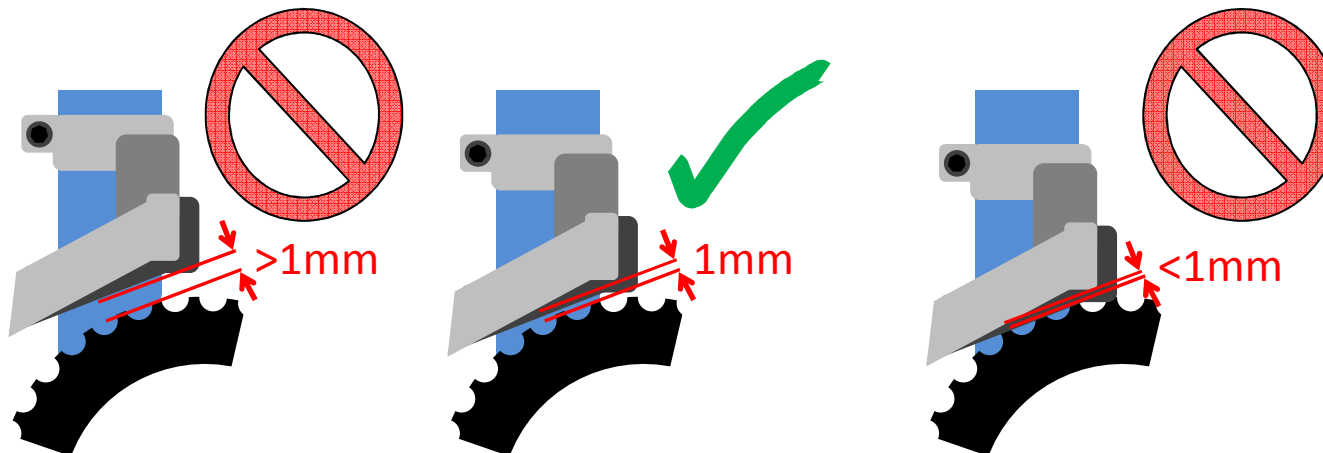

# Q-Rings

## FRONT DERAILLEUR SETUP

- All chainrings, round or oval require a quality FD setup. With oval rings, Sloppy setup = disastrous shifting!
- No specialist skills are required. When setup is correct, Q-Rings shift just as well as all other round chainrings.

### 6 SETUP RULES:

- 1) Perfectly parallel chainrings and derailleur cage.
- 2) Derailleur limitation screws must be set up to prevent over and under shifts.
- 3) No more than 1,5mm clearance form top of teeth to bottom of cage at max diameter
- 4) No more than 1,5mm clearance from chain to cage at high end (53-11 / 44-11)
- 5) No more than 1,5mm clearance from chain to cage at low end (39-25 / 23-34)

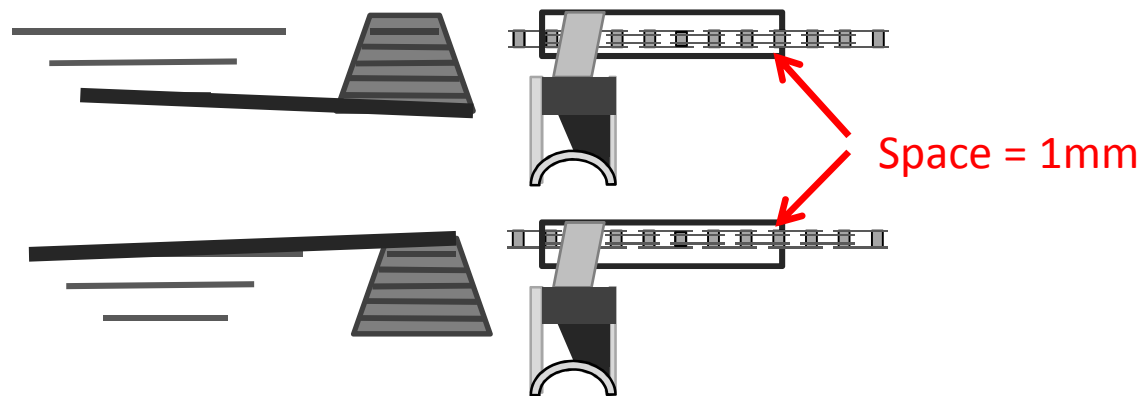

# Q-Rings

## FRONT DERAILLEUR SETUP

- All chainrings, round or oval require a quality FD setup. With oval rings, Sloppy setup = disastrous shifting!
- No specialist skills are required. When setup is correct, Q-Rings shift just as well as all other round chainrings.

### 6 SETUP RULES:

- 1) Perfectly parallel chainrings and derailleur cage.
- 2) Derailleur limitation screws must be set up to prevent over and under shifts.
- 3) No more than 1,5mm clearance from top of teeth to bottom of cage at max diameter
- 4) No more than 1,5mm clearance from chain to cage at high end (53-11 / 44-11)
- 5) No more than 1,5mm clearance from chain to cage at low end (39-25 / 23-34)
- 6) Be exact with non-trimming derailleurs

# Q-Rings

## FRONT DERAILLEUR SETUP

- All chainrings, round or oval require a quality FD setup. With oval rings, Sloppy setup = disastrous shifting!
- No specialist skills are required. When setup is correct, Q-Rings shift just as well as all other round chainrings.

### 6 SETUP RULES:

- 1) Perfectly parallel chainrings and derailleur cage.
- 2) Derailleur limitation screws must be set up to prevent over and under shifts.
- 3) No more than 1,5mm clearance from top of teeth to bottom of cage at max diameter
- 4) No more than 1,5mm clearance from chain to cage at high end (53-11 / 44-11)
- 5) No more than 1,5mm clearance from chain to cage at low end (39-25 / 23-34)
- 6) Be exact with non-trimming derailleurs
- 7) Braze on tab problems? A) Too low: fix with Dremel (ask frame manufacturer, you may void your warranty).  
B) Wrong angle: fix with SRAM Braze-on Front Derailleur washer for compact crank  
SRAM product number 11.7615.011.000